

rysunek

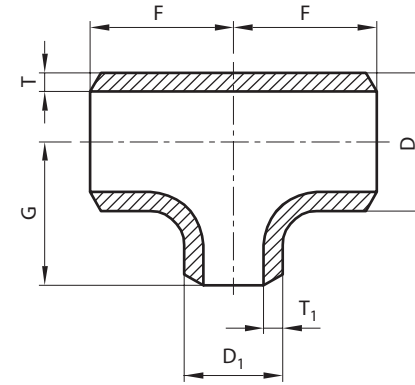
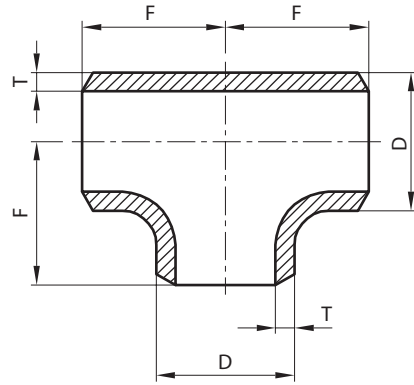

Trójniki typ A

DN	D	D _i	Wymiary w mm		Grubości ścianek T, T ₁ wg szeregów, współczynnik ciśnienia X w %, przybliżona masa w kg															
			F	G	1				2				3				4			
					T	T ₁	X %	kg	T	T ₁	X %	kg	T	T ₁	X %	kg	T	T ₁	X %	kg
15	21,3	21,3	25	25	-	-	-	-	2,0	2,0	42	0,09	2,6	2,6	46	0,11	3,2	3,2	48	0,15
20	26,9	26,9	29	29	-	-	-	-	2,3	2,3	43	0,15	2,6	2,6	44	0,17	3,2	3,2	47	0,21
		21,3							2,3	2,0	44		2,6	2,6	50		3,2	3,2	53	
25	33,7	33,7	38	38	-	-	-	-	2,6	2,6	41	0,29	3,2	3,2	43	0,35	4,0	4,0	46	0,42
		26,9							2,6	2,3	42		3,2	2,6	42		4,0	3,2	45	
		21,3							2,6	2,0	43		3,2	2,6	47		4,0	3,2	50	
32	42,4	42,4	48	48	-	-	-	-	2,6	2,6	38	0,42	3,6	3,6	42	0,57	4,0	4,0	43	0,63
		33,7							2,6	2,6	42		3,6	3,2	43		4,0	4,0	48	
		26,9							2,6	2,3	43		3,6	2,6	43		4,0	3,2	47	
		21,3							2,6	2,0	44		3,6	2,6	47		4,0	3,2	51	
40	48,3	48,3	57	57	-	-	-	-	2,6	2,6	35	0,59	3,6	3,6	39	0,80	4,0	4,0	40	0,90
		42,4							2,6	2,6	38		3,6	3,6	42		4,0	4,0	43	
		33,7							2,6	2,6	42		3,6	3,2	43		4,0	4,0	48	
		26,9							2,6	2,3	42		3,6	2,6	42		4,0	3,2	46	
		21,3							2,6	2,0	42		3,6	2,6	46		4,0	3,2	50	
50	60,3	60,3	64	64	-	-	-	-	2,9	2,9	36	0,90	3,6	3,6	39	1,10	4,0	4,0	40	1,20
		48,3		60					2,9	2,6	39		3,6	3,6	45		4,0	4,0	47	
		42,4		57					2,9	2,6	43		3,6	3,6	49		4,0	4,0	51	
		33,7		51					2,9	2,6	51		3,6	3,2	54		4,0	4,0	60	
		26,9		44					2,9	2,3	58		3,6	2,6	59		4,0	3,2	63	
65	76,1	76,1	76	76	-	-	-	-	2,9	2,9	34	1,35	3,6	3,6	37	2,00	5,6	5,6	43	2,40
		60,3		70					2,9	2,9	41		3,6	3,6	44		5,6	4,0	46	
		48,3		67					2,9	2,6	44		3,6	3,6	50		5,6	4,0	48	
		42,4		64					2,9	2,6	48		3,6	3,6	55		5,6	4,0	52	
		33,7		57					2,9	2,6	57		3,6	3,2	60		5,6	4,0	61	
80	88,9	88,9	86	86	-	-	-	-	3,2	3,2	34	1,95	4,0	4,0	37	2,60	5,6	5,6	41	3,70
		76,1		83					3,2	2,9	36		4,0	3,6	38		5,6	5,6	46	
		60,3		76					3,2	2,9	42		4,0	3,6	45		5,6	4,0	45	
		48,3		73					3,2	2,6	46		4,0	3,6	52		5,6	4,0	51	
		42,4		70					3,2	2,6	50		4,0	3,6	56		5,6	4,0	55	
	108,0	108,0	100	100	-	-	-	-	3,6	3,6	-	2,90	-	-	-	-	-	-	-	-

^aSzczegóły obliczeniowe współczynnika X - patrz Załączniki A, B w EN 10253-2.

DN	D	D ₁	Wymiary w mm		Grubości ścianek T, T ₁ wg szeregów, współczynnik ciśnienia X w %, przybliżona masa w kg															
			F	G	1				2				3				4			
					T	T ₁	X %	kg	T	T ₁	X %	kg	T	T ₁	X %	kg	T	T ₁	X %	kg
100	114,3	114,3	105	105	-	-	-	-	3,6	3,6	34	3,30	4,5	4,5	36	3,90	6,3	6,3	40	5,70
		88,9		98	-	-	-	3,6	3,2	37	4,5		4,0	40	6,3		5,6	45		
		76,1		95	-	-	-	3,6	2,9	39	4,5		3,6	42	6,3		5,6	49		
		60,3		89	-	-	-	3,6	2,9	45	4,5		3,6	49	6,3		4,0	49		
		48,3		86	-	-	-	3,6	2,6	49	4,5		3,6	55	6,3		4,0	55		
	133,0	133,0	120	120	-	-	-	-	4,0	4,0	-	4,60	-	-	-	-	-	-	-	-
125	139,7	139,7	124	124	-	-	-	-	4,0	4,0	33	5,10	5,0	5,0	36	5,50	6,3	6,3	39	7,90
		114,3		117	-	-	-	4,0	3,6	36	5,0		4,5	38	6,3		6,3	44		
		88,9		111	-	-	-	4,0	3,2	39	5,0		4,0	42	6,3		5,6	48		
		76,1		108	-	-	-	4,0	2,9	41	5,0		3,6	44	6,3		5,6	53		
		60,3		105	-	-	-	4,0	2,9	47	5,0		3,6	50	6,3		4,0	51		
	159,0	159,0	138	138	-	-	-	-	4,5	4,5	-	7,50	-	-	-	-	-	-	-	-
150	168,3	168,3	143	143	4,0	4,0	32	7,50	4,5	4,5	33	8,10	5,6	5,6	36	11,80	7,1	7,1	38	13,00
		139,7		137	-	-	-	4,5	4,0	35	5,6		5,0	38	7,1		6,3	40		
		114,3		130	-	-	-	4,5	3,6	38	5,6		4,5	41	7,1		6,3	46		
		88,9		124	-	-	-	4,5	3,2	42	5,6		4,0	45	7,1		5,6	51		
		76,1		121	-	-	-	4,5	2,9	44	5,6		3,6	47	7,1		5,6	55		
		60,3		115	-	-	-	4,5	2,9	-	5,6		3,6	-	7,1		4,0	-		
200	219,1	219,1	178	178	4,5	4,5	31	13,5	6,3	6,3	34	18,0	7,1	7,1	36	20,00	8,0	8,0	37	23,50
		168,3		168	4,5	4,0	34	6,3	4,5	37	7,1		5,6	37	8,0		7,1	41		
		139,7		162	-	-	-	6,3	4,0	37	7,1		5,0	40	8,0		6,3	44		
		114,3		156	-	-	-	6,3	3,6	40	7,1		4,5	43	8,0		6,3	50		
		88,9		152	-	-	-	6,3	3,2	-	7,1		4,0	-	8,0		5,6	-		
250	273,0	273,0	216	216	5,0	5,0	30	21,5	6,3	6,3	32	26,5	8,8	8,8	36	36,5	10,0	10,0	38	41,5
		219,1		203	5,0	4,5	33	6,3	6,3	38	8,8		7,1	37	10,0		8,0	39		
		168,3		194	5,0	4,0	36	6,3	4,5	37	8,8		5,6	40	10,0		7,1	43		
		139,7		191				6,3	4,0	40	8,8		5,0	42	10,0		6,3	46		
		114,3		184				6,3	3,6	43	8,8		4,5	47	10,0		6,3	52		

*Szczegóły obliczeniowe współczynnika X - patrz Załączniki A, B w EN 10253-2.

DN 300 - DN 550 / Szeregi 1-4

DN	D	D ₁	Wymiary w mm		Grubości ścianek T, T ₁ wg szeregów, współczynnik ciśnienia X w %, przybliżona masa w kg																	
			F	G	1				2				3				4					
					T	T ₁	X %	kg	T	T ₁	X %	kg	T	T ₁	X %	kg	T	T ₁	X %	kg		
300	323,9	323,9	254	254	5,6	5,6	29	35,0	7,1	7,1	32	42,0	8,8	8,8	34	55,0	10,0	10,0	36	59,0		
		273,0		241	5,6	5,0	31		7,1	6,3	33		8,8	8,8	39		10,0	10,0	41			
		219,1		229	5,6	4,5	34		7,1	6,3	39		8,8	7,1	40		10,0	8,0	41			
		168,3		219	5,6	4,0	38		7,1	4,5	39		8,8	5,6	42		10,0	7,1	46			
		139,7		216	-	-	-		7,1	4,0	-		-	-	-		10,0	6,3	-			
		114,3		210	-	-	-		7,1	3,6	-		-	-	-		10,0	6,3	-			
		350		355,6	355,6	279	279		5,6	5,6	28		44	8,0	8,0		32	60	10,0		10,0	35
323,9	270		5,6		5,6		30	8,0	7,1	33	10,0	8,8		35	12,5	10,0	40					
273,0	257		5,6		5,0		32	8,0	6,3	34	10,0	8,8		39	12,5	10,0	40					
219,1	248		5,6		4,5		35	8,0	6,3	39	10,0	7,1		40	12,5	8,0	41					
168,3	238		5,6		4,0		39	8,0	4,5	40	10,0	5,6		43	12,5	7,1	47					
400	406,4		406,4		305		305	6,3	6,3	28	61	8,8		8,8	32	82	10,0		10,0	34	93	12,5
		355,6	305	6,3		5,6	29	8,8	8,0	33		10,0	10,0	37	12,5		12,5	39				
		323,9	295	6,3		5,6	31	8,8	7,1	33		10,0	8,8	36	12,5		10,0	37				
		273,0	283	6,3		5,0	33	8,8	6,3	35		10,0	8,8	41	12,5		10,0	42				
		219,1	273	6,3		4,5	36	8,8	6,3	40		10,0	7,1	42	12,5		8,0	43				
		168,3	264	6,3		4,0	40	8,8	4,5	42		10,0	5,6	45	12,5		7,1	49				
		450	457,0	457,0		343	343	6,3	6,3	27		77	10,0	10,0	32		135	11,0	11,0	33		164
406,4	330			6,3	6,3		30	10,0	8,8	33	11,0		10,0	34	12,5	12,5		38				
355,6	330			6,3	5,6		30	10,0	8,0	33	11,0		10,0	37	154	12,5		12,5	41	164		
323,9	321			6,3	5,6		32	10,0	7,1	34	11,0		8,8	37	140	12,5		10,0	39	154		
273,0	308			6,3	5,0		34	10,0	6,3	36	11,0		8,8	42		12,5		10,0	43			
219,1	298			6,3	4,5		37	10,0	6,3	42	11,0		7,1	43		12,5		8,0	45			
500	508,0			508,0	381		381	6,3	6,3	26	104		10,0	10,0	31	165		11,0	11,0	32	185	
		457,0	368	6,3		6,3	28	10,0	10,0	34		11,0	11,0	35	12,5		12,5	36				
		406,4	356	6,3		6,3	31	10,0	8,8	34		11,0	10,0	36	12,5		12,5	40				
		323,9	346	6,3		5,6	33	10,0	7,1	35		11,0	8,8	39	12,5		10,0	40				
		273,0	333	6,3		5,0	35	10,0	6,3	38		11,0	8,8	43	12,5		10,0	45				
		550	559,0	559,0		419	419	6,3	6,3	-		-	10,0	10,0	-		200	-	-	-		-
508,0	406			6,3	6,3		-	10,0	10,0	-	-		-	-	12,5	12,5		-				
406,4	381			6,3	6,3		-	10,0	8,8	-	185		-	-	-	12,5		12,5	-			
323,9	371			6,3	5,6		-	10,0	7,1	-	170		-	-	-	12,5		10,0	-			
273,0	359			6,3	5,0		-	10,0	6,3	-			-	-	-	12,5		10,0	-			

DN	D	D ₁	Wymiary w mm		Grubości ścianek T, T ₁ wg szeregów, współczynnik ciśnienia X w %, przybliżona masa w kg															
			F	G	1				2				3				4			
					T	T ₁	X %	kg	T	T ₁	X %	kg	T	T ₁	X %	kg	T	T ₁	X %	kg
600	610,0	610,0	432	432	6,3	6,3	25	138	10,0	10,0	30	240	12,5	12,5	32	350	17,5	17,5	36	570
		508,0		432	6,3	6,3	28		10,0	10,0	33		12,5	11,0	33		17,5	12,5	39	390
		406,4		406	6,3	6,3	33		10,0	8,8	36	230	12,5	10,0	37	320	17,5	12,5	39	310
		323,9		397	6,3	5,6	36		10,0	7,1	36	220	12,5	8,8	40	300	17,5	10,0	42	
		273,0		384	6,3	5,0	38		10,0	6,3	40		12,5	8,8	45		17,5	10,0	46	
650	660,0	660,0	495	495	-	-	-	-	10,0	10,0	-	290	12,5	12,5	-	360	17,5	17,5	-	-
		508,0		457	-	-	-		10,0	10,0	-	260	12,5	11,0	-	330	17,5	12,5	-	
		406,4		432	-	-	-		10,0	8,8	-	245	12,5	10,0	-	310	17,5	12,5	-	
		355,6		432	-	-	-		10,0	8,0	-		12,5	10,0	-		17,5	12,5	-	
		323,9		422	-	-	-		10,0	7,1	-		12,5	8,8	-		17,5	10,0	-	
700	711,0	711,0	521	521	7,1	7,1	24	-	10,0	10,0	28	340	12,5	12,5	30	420	25,0	25,0	38	-
		610,0		508	7,1	6,3	25		10,0	10,0	30	320	12,5	12,5	33	400	25,0	17,5	43	
		508,0		483	7,1	6,3	28		10,0	10,0	34	300	12,5	11,0	35	380	25,0	12,5	50	
		406,4		457	7,1	6,3	33		10,0	8,8	37	285	12,5	10,0	39	360	25,0	12,5	47	
		323,9		448	7,1	5,6	36		10,0	7,1	39		12,5	8,8	42		25,0	10,0	50	
750	762,0	762,0	559	559	-	-	-	-	10,0	10,0	-	390	12,5	12,5	-	480	25,0	25,0	-	-
		610,0		533	-	-	-		10,0	10,0	-	360	12,5	12,5	-	460	25,0	17,5	-	
		508,0		508	-	-	-		10,0	10,0	-	340	12,5	11,0	-	430	25,0	12,5	-	
		406,4		483	-	-	-		10,0	8,8	-	320	12,5	10,0	-	415	25,0	12,5	-	
800	813,0	813,0	602	602	8,0	8,0	24	-	10,0	10,0	26	450	12,5	12,5	29	550	25,0	25,0	37	-
		711,0		572	8,0	7,1	25		10,0	10,0	29	430	12,5	12,5	32		25,0	25,0	40	
		610,0		559	8,0	6,3	26		10,0	10,0	32	410	12,5	12,5	34	510	25,0	17,5	39	
		508,0		533	8,0	6,3	29		10,0	10,0	36		12,5	11,0	36	490	25,0	12,5	46	
		406,4		508	8,0	6,3	34		10,0	8,8	39		380	12,5	10,0	40	460	25,0	12,5	
850	864,0	864,0	635	635	-	-	-	-	10,0	10,0	-	520	12,5	12,5	-	650	25,0	25,0	-	-
		711,0		597	-	-	-		10,0	10,0	-	480	12,5	12,5	-	600	25,0	25,0	-	
		610,0		584	-	-	-		10,0	10,0	-	460	12,5	12,5	-	575	25,0	17,5	-	
		508,0		559	-	-	-		10,0	10,0	-	430	12,5	11,0	-	545	25,0	12,5	-	
		406,4		533	-	-	-		10,0	8,8	-	410	12,5	10,0	-	520	25,0	12,5	-	

DN 900 - DN 1200 / Szeregi 1-4

DN	D	D ₁	Wymiary w mm		Grubości ścianek T, T ₁ wg szeregów, współczynnik ciśnienia X w %, przybliżona masa w kg															
			F	G	1				2				3				4			
					T	T ₁	X %	kg	T	T ₁	X %	kg	T	T ₁	X %	kg	T	T ₁	X %	kg
900	914,0	914,0	673	673	10,0	10,0	25	585	12,5	12,5	27	730	20,0	20,0	33	-	25,0	25,0	35	-
		813,0		648	10,0	8,0	27	541	12,5	10,0	29	700	20,0	12,5	39		25,0	25,0	38	
		711,0		622	10,0	7,1	27	500	12,5	10,0	29	670	20,0	12,5	38		25,0	25,0	42	
		610,0		610	10,0	6,3	28	490	12,5	10,0	32	640	20,0	12,5	36		25,0	17,5	38	
		508,0		584	10,0	6,3	30	475	12,5	10,0	36	610	20,0	11,0	37		25,0	12,5	43	
		406,4		559	10,0	6,3	36		12,5	8,8	40	590	20,0	10,0	42		25,0	12,5	45	
1000	1016,0	1016,0	749	749	10,0	10,0	24	690	12,5	12,5	26	895	20,0	20,0	30	-	25,0	25,0	34	-
		914,0		737	10,0	10,0	26	-	12,5	12,5	28	-	20,0	20,0	34		25,0	25,0	36	
		813,0		711	10,0	8,0	25		12,5	10,0	27		20,0	12,5	37		25,0	25,0	40	
		711,0		673	10,0	7,1	26		12,5	10,0	30		20,0	12,5	33		25,0	25,0	44	
		610,0		660	10,0	6,3	27		12,5	10,0	33		20,0	12,5	34		25,0	17,5	39	
1050	1067,0	1067,0	762	711	10,0	10,0	-	795	12,5	12,5	-	1045	20,0	20,0	-	-	25,0	25,0	-	-
		914,0		711	10,0	10,0	-	-	12,5	12,5	-	-	20,0	20,0	-		25,0	25,0	-	
		813,0		711	10,0	8,0	-		12,5	10,0	-		20,0	12,5	-		25,0	25,0	-	
		711,0		698	10,0	7,1	-		12,5	10,0	-		20,0	12,5	-		25,0	25,0	-	
		610,0		660	10,0	6,3	-		12,5	10,0	-		20,0	12,5	-		25,0	17,5	-	
1100	1118,0	1118,0	813	762	10,0	10,0	-	900	12,5	12,5	-	1195	20,0	20,0	-	-	25,0	25,0	-	-
		914,0		724	10,0	10,0	-	-	12,5	12,5	-	-	20,0	20,0	-		25,0	25,0	-	
		813,0		711	10,0	8,0	-		12,5	10,0	-		20,0	12,5	-		25,0	25,0	-	
		711,0		698	10,0	7,1	-		12,5	10,0	-		20,0	12,5	-		25,0	25,0	-	
		610,0		698	10,0	6,3	-		12,5	10,0	-		20,0	12,5	-		25,0	17,5	-	
1150	1168,0	1168,0	851	800	10,0	10,0	-	1010	12,5	12,5	-	1345	20,0	20,0	-	-	25,0	25,0	-	-
1200	1219,0	1219,0	889	838	10,0	10,0	23	1113	12,5	12,5	25	1500	20,0	20,0	30	-	25,0	25,0	33	-
		1016,0		813	10,0	10,0	26	-	12,5	12,5	29	-	20,0	20,0	34		25,0	25,0	37	
		914,0		787	10,0	10,0	28		12,5	12,5	31		20,0	20,0	37		25,0	25,0	40	
		813,0		787	10,0	8,0	27		12,5	10,0	29		20,0	12,5	33		25,0	25,0	43	
		711,0		762	10,0	7,1	28		12,5	10,0	32		20,0	12,5	34		25,0	25,0	47	

^a Szczegóły obliczeniowe współczynnika X - patrz Załączniki A, B w EN 10253-2.

DN	D	D ₁	Wymiary w mm		Grubości ścianek T, T ₁ wg szeregów, współczynnik ciśnienia X w %, przybliżona masa w kg															
			F	G	5				6				7				8			
					T	T ₁	X %	kg	T	T ₁	X %	kg	T	T ₁	X %	kg	T	T ₁	X %	kg
15	21,3	21,3	25	25	4,0	4,0	51	0,18	-	-	-	-	5,0	5,0	53	0,22	7,1	7,1	57	0,27
20	26,9	26,9	29	29	4,0	4,0	50	0,25	4,5	4,5	51	0,09	5,6	5,6	54	0,33	8,0	8,0	58	0,39
		21,3			4,0	4,0	57		-	-	-	-	5,6	5,0	57		8,0	7,1	61	
25	33,7	33,7	38	38	4,5	4,5	47	0,50	5,6	5,6	50	0,55	6,3	6,3	52	0,61	8,8	8,8	56	0,78
		26,9			4,5	4,0	49		5,6	4,5	49		6,3	5,6	54		8,8	8,0	59	
		21,3			4,5	4,0	55		-	-	-		-	6,3	5,0		56	8,8	7,1	
32	42,4	42,4	48	48	5,0	5,0	46	0,77	6,3	6,3	49	0,93	8,0	8,0	52	1,20	10,0	10,0	54	1,35
		33,7			5,0	4,5	48		6,3	5,6	51		8,0	6,3	51		10,0	8,8	56	
		26,9			5,0	4,0	50		6,3	4,5	50		8,0	5,6	52		10,0	8,0	59	
		21,3			5,0	4,0	54		-	-	-		-	8,0	5,0		55	10,0	7,1	
40	48,3	48,3	57	57	5,0	5,0	43	1,10	6,3	6,3	46	1,30	8,0	8,0	49	1,60	10,0	10,0	52	1,90
		42,4			5,0	5,0	46		6,3	6,3	49		8,0	8,0	52		10,0	10,0	55	
		33,7			5,0	4,5	48		6,3	5,6	51		8,0	6,3	50		10,0	8,8	57	
		26,9			5,0	4,0	49		6,3	4,5	49		8,0	5,6	52		10,0	8,0	59	
		21,3			5,0	4,0	53		-	-	-		-	8,0	5,0		54	10,0	7,1	
50	60,3	60,3	64	64	5,6	5,6	44	1,65	7,1	7,1	47	1,90	8,8	8,8	50	2,45	11,0	11,0	53	2,95
		48,3		60	5,6	5,0	48		7,1	6,3	51		8,8	8,0	55		11,0	10,0	58	
		42,4		57	5,6	5,0	53		7,1	6,3	56		8,8	8,0	60		11,0	10,0	64	
		33,7		51	5,6	4,5	59		7,1	5,6	62		8,8	6,3	62		11,0	8,8	69	
		26,9		44	5,6	4,0	66		7,1	4,5	70		8,8	5,6	70		11,0	8,0	78	
65	76,1	76,1	76	76	7,1	7,1	46	3,15	8,0	8,0	47	3,65	10,0	10,0	50	4,25	14,2	14,2	55	5,65
		60,3		70	7,1	5,6	47		8,0	7,1	52		10,0	8,8	55		14,2	11,0	57	
		48,3		67	7,1	5,0	51		8,0	6,3	55		10,0	8,0	59		14,2	10,0	60	
		42,4		64	7,1	5,0	55		8,0	6,3	60		10,0	8,0	64		14,2	10,0	66	
		33,7		57	7,1	4,5	62		8,0	5,6	67		10,0	6,3	67		14,2	8,8	73	
80	88,9	88,9	86	86	8,0	8,0	46	4,60	8,8	8,8	47	5,00	11,0	11,0	50	6,10	16,0	16,0	55	8,30
		76,1		83	8,0	7,1	47		8,8	8,0	49		11,0	10,0	52		16,0	14,2	56	
		60,3		76	8,0	5,6	49		8,8	7,1	54		11,0	8,8	57		16,0	11,0	58	
		48,3		73	8,0	5,0	53		8,8	6,3	58		11,0	8,0	62		16,0	10,0	63	
		42,4		70	8,0	5,0	58		8,8	6,3	63		11,0	8,0	67		16,0	10,0	68	

*Szczegóły obliczeniowe współczynnika X - patrz Załączniki A, B w EN 10253-2.

DN 100 - DN 300 / Szeregi 5-8

DN	D	D ₁	Wymiary w mm		Grubości ścianek T, T ₁ wg szeregów, współczynnik ciśnienia X w %, przybliżona masa w kg															
			F	G	5				6				7				8			
					T	T ₁	X %	kg	T	T ₁	X %	kg	T	T ₁	X %	kg	T	T ₁	X %	kg
100	114,3	114,3	105	105	8,8	8,8	45	7,70	11,0	11,0	48	9,45	14,2	14,2	51	12,00	17,5	17,5	54	14,10
		88,9		98	8,8	8,0	50		11,0	8,8	50		14,2	11,0	52		17,5	16,0	60	
		76,1		95	8,8	7,1	52		11,0	8,0	52		14,2	10,0	55		17,5	14,2	62	
		60,3		89	8,8	5,6	54		11,0	7,1	57		14,2	8,8	60		17,5	11,0	63	
		48,3		86	8,8	5,0	58		11,0	6,3	61		14,2	8,0	65		17,5	10,0	69	
125	139,7	139,7	124	124	10,0	10,0	44	12,00	12,5	12,5	47	14,50	16,0	16,0	51	18,50	20,0	20,0	53	25,00
		114,3		117	10,0	8,8	47		12,5	11,0	50		16,0	14,2	54		20,0	17,5	57	
		88,9		111	10,0	8,0	52		12,5	8,8	52		16,0	11,0	55		20,0	16,0	63	
		76,1		108	10,0	7,1	54		12,5	8,0	55		16,0	10,0	58		20,0	14,2	65	
		60,3		105	10,0	5,6	56		12,5	7,1	60		16,0	8,8	63		20,0	11,0	66	
150	168,3	168,3	143	143	11,0	11,0	44	19,00	14,2	14,2	47	24,50	17,5	17,5	50	29,50	22,2	22,2	52	36,00
		139,7		137	11,0	10,0	47		14,2	12,5	50		17,5	16,0	54		22,2	20,0	56	
		114,3		130	11,0	8,8	50		14,2	11,0	53		17,5	14,2	57		22,2	17,5	60	
		88,9		124	11,0	8,0	55		14,2	8,8	56		17,5	11,0	59		22,2	16,0	66	
		76,1		121	11,0	7,1	57		14,2	8,0	59		17,5	10,0	62		22,2	14,2	68	
200	219,1	219,1	178	178	12,5	12,5	43	35,50	16,0	16,0	46	43,00	17,5	17,5	47	49,00	22,2	22,2	49	60,5
		168,3		168	12,5	11,0	47		16,0	14,2	51		17,5	17,5	57		22,2	22,2	59	
		139,7		162	12,5	10,0	51		16,0	12,5	54		17,5	16,0	60		22,2	20,0	63	
		114,3		156	12,5	8,8	54		16,0	11,0	57		17,5	14,2	63		22,2	17,5	66	
		88,9		152	12,5	8,0	-		-	-	-		-	-	-		-	-	-	
250	273,0	273,0	216	216	12,5	12,5	41	51,0	16,0	16,0	44	65,0	22,2	22,2	47	92,0	30,0	30,0	48	115
		219,1		203	12,5	12,5	47		16,0	16,0	51		22,2	17,5	50		30,0	22,2	55	
		168,3		194	12,5	11,0	52		16,0	14,2	56		22,2	17,5	57		30,0	22,2	59	
		139,7		191	12,5	10,0	54		16,0	12,5	58		22,2	16,0	61		30,0	20,0	63	
		114,3		184	12,5	8,8	58		16,0	11,0	61		22,2	14,2	64		30,0	17,5	67	
300	323,9	323,9	254	254	12,5	12,5	39	73,0	17,5	17,5	43	107	25,0	25,0	46	140	32,0	32,0	47	174
		273,0		241	12,5	12,5	44		17,5	16,0	46		25,0	22,2	49		32,0	30,0	53	
		219,1		229	12,5	12,5	50		17,5	16,0	53		25,0	17,5	51		32,0	22,2	53	
		168,3		219	12,5	11,0	55		17,5	14,2	58		25,0	17,5	59		32,0	22,2	62	
		139,7		216	12,5	10,0	-		-	-	-		-	-	-		-	-	-	
		114,3		210	12,5	8,8	-		-	-	-		-	-	-		-	-	-	

^a Szczegóły obliczeniowe współczynnika X - patrz Załączniki A, B w EN 10253-2.

DN 350 - DN 600 / Szeregi 5-8

DN	D	D ₁	Wymiary w mm		Grubości ścianek T, T ₁ wg szeregów, współczynnik ciśnienia X w %, przybliżona masa w kg															
			F	G	5				6				7				8			
					T	T ₁	X %	kg	T	T ₁	X %	kg	T	T ₁	X %	kg	T	T ₁	X %	kg
350	355,6	355,6	279	279	16,0	16,0	41	122	20,0	20,0	43	148	28,0	28,0	47	200	36,0	36,0	47	250
		323,9		270	16,0	12,5	44		20,0	17,5	45		28,0	25,0	48		36,0	32,0	51	
		273,0		257	16,0	12,5	42	108	20,0	16,0	46	130	28,0	22,2	50	187	36,0	30,0	53	235
		219,1		248	16,0	12,5	49		20,0	16,0	53		28,0	17,5	52		36,0	22,2	54	
		168,3		238	16,0	11,0	54		-	-	-		-	28,0	17,5		60	36,0	22,2	
400	406,4	406,4	305	305	17,5	17,5	41	182	22,2	22,2	43	195	30,0	30,0	44	280	40,0	40,0	45	345
		355,6		305	17,5	16,0	42		22,2	20,0	44		30,0	28,0	49		40,0	36,0	50	
		323,9		295	17,5	12,5	44	172	22,2	17,5	45	181	30,0	25,0	49	229	40,0	32,0	51	282
		273,0		283	17,5	12,5	44		22,2	16,0	47		30,0	22,2	52		40,0	30,0	55	
		219,1		273	17,5	12,5	50	162	22,2	16,0	54	163	30,0	17,5	54	204	40,0	22,2	57	275
		168,3		264	17,5	11,0	55		22,2	14,2	59		30,0	17,5	62		40,0	22,2	65	
450	457,0	457,0	343	343	17,5	17,5	39	256	22,2	22,2	42	298	32,0	32,0	44	420	45,0	45,0	45	590
		406,4		330	17,5	17,5	43		22,2	22,2	46		32,0	30,0	47		45,0	40,0	49	
		355,6		330	17,5	16,0	44	212	22,2	20,0	47	226	32,0	28,0	50	340	45,0	36,0	52	520
		323,9		321	17,5	12,5	41		22,2	17,5	46		32,0	25,0	51		45,0	32,0	52	
		273,0		308	17,5	12,5	46	187	22,2	16,0	49	226	32,0	22,2	53	340	45,0	30,0	57	475
		219,1		298	17,5	12,5	52		22,2	16,0	56		32,0	17,5	56		45,0	22,2	59	
500	508,0	508,0	381	381	17,5	17,5	38	333	25,0	25,0	42	425	36,0	36,0	44	527	50,0	50,0	45	790
		457,0		368	17,5	17,5	41		25,0	22,2	43		36,0	32,0	47		50,0	45,0	49	
		406,4		356	17,5	17,5	44	250	25,0	22,2	46	310	36,0	30,0	48	428	50,0	40,0	50	750
		323,9		346	17,5	12,5	42		25,0	17,5	47		36,0	25,0	52		50,0	32,0	54	
		273,0		333	17,5	12,5	48	25,0	16,0	50	36,0	22,2	55	50,0	30,0	58				
600	610,0	610,0	432	432	25,0	25,0	39	650,0	30,0	30,0	40	730,0	45,0	45,0	41	1100	60,0	60,0	42	1300
		508,0		432	25,0	17,5	45	550,0	30,0	25,0	43	600	45,0	36,0	48	1060	60,0	50,0	49	
		406,4		406	25,0	17,5	44	430,0	30,0	22,2	47	490	45,0	30,0	50	1000	60,0	40,0	53	1200
		323,9		397	25,0	12,5	47		30,0	17,5	49		45,0	25,0	54		60,0	32,0	57	
		273,0		384	25,0	12,5	50	430,0	30,0	16,0	53	450	45,0	22,2	57	950	60,0	30,0	61	1050

^a Szczegóły obliczeniowe współczynnika X - patrz Załączniki A, B w EN 10253-2.