

powierzchnie uszczelniające kotnierzy

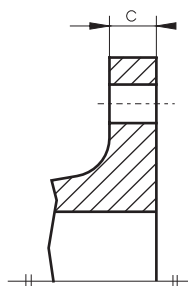

Typ A: Płaska

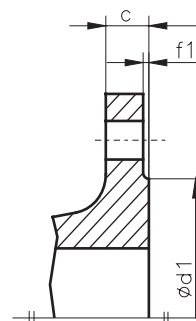

Typ B: Przyłga (B1 i B2)

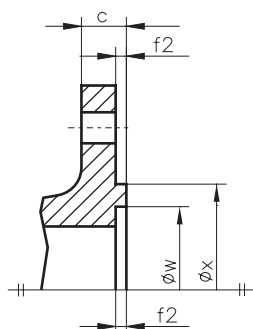

Typ C: Występ

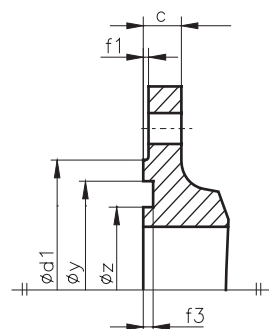

Typ D: Rowek

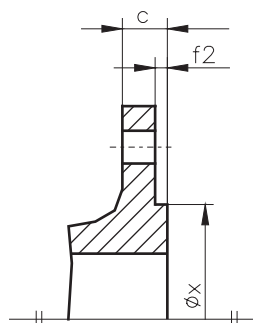

Typ E: Wypust

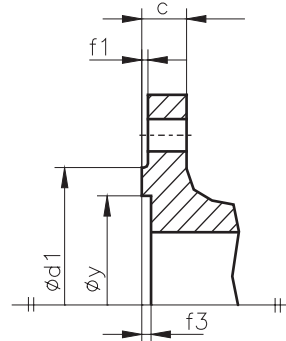

Typ F: Wpust

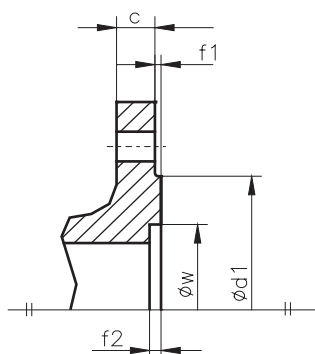

Typ G: Wypust do uszczelki o przekroju kołowym

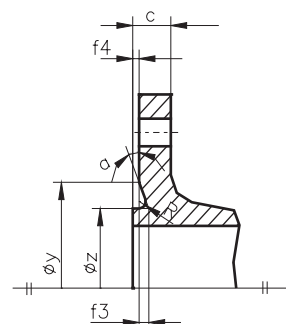

Typ H: Rowek na uszczelkę o przekroju kołowym

UWAGA 1 Wymiar C zawiera wysokość przyłgi.

UWAGA 2 Średnica przekroju poprzecznego uszczelki o przekroju kołowym wynosi $2 \times R$.

UWAGA 3 Przejście od krawędzi powierzchni uszczelniającej na czoło kotnierza może być w postaci promienia lub fazy wyłącznie dla typów B, D, F i G

zestawienie wymiarów

DN	d_1											f_1	f_2	f_3	f_4	W^b	X	Y	Z^b	$\alpha \approx$	R		
	PN 2,5 ^a	PN6 ^a	PN 10	PN 16	PN 25	PN 40	PN 63	PN 100	PN 160	PN 250	PN 320											PN 400	
	mm	mm	mm	mm	mm	mm	mm	mm	mm	mm	mm	mm	mm	mm	mm	mm	mm	mm	mm	mm			
10	35	35	40	40	40	40	40	40	40	40	40	40	2	4,5	4,0	2,0	24	34	35	23	-	2,5	
15	40	40	45	45	45	45	45	45	45	45	45	45					29	39	40	28	-		
20	50	50	58	58	58	58	58	58	58	58	58	58					36	50	51	35	41°		
25	60	60	68	68	68	68	68	68	68	68	68	68					43	57	58	42			
32	70	70	78	78	78	78	78	78	78	78	78	78					51	65	66	50			
40	80	80	88	88	88	88	88	88	88	88	88	88	3				61	75	76	60			
50	90z	90	102	102	102	102	102	102	102	102	102	102					73	87	88	72			
65	110	110	122	122	122	122	122	122	122	122	122	122					95	109	110	94			
80	128	128	138	138	138	138	138	138	138	138	138	138					106	120	121	105			
100	148	148	158	158	162	162	162	162	162	162	162	162		5,0	4,5	2,5	129	149	150	128	32°	3	
125	178	178	188	188	188	188	188	188	188	188	188	188					155	175	176	154			
150	202	202	212	212	218	218	218	218	218	218	218	218					183	203	204	182			
200	258	258	268	268	278	285	285	285	285	285	285	285					239	259	260	238			
250	312	312	320	320	335	345	345	345	345	345	345	345					292	312	313	291			
300	365	365	370	378	395	410	410	410	410	410	410	410	4				343	363	364	342			
350	415	415	430	438	450	465	465	465	465	465	465	465		5,5	5,0	3,0	395	421	422	394	27°	3,5	
400	465	465	482	490	505	535	535	535	535	535	535	535					447	473	474	446			
450	520	520	532	550	555	560	560	560	560	560	560	560					497	523	524	496			
500	570	570	585	610	615	615	615	615	615	615	615	615					549	575	576	548			
600	670	670	685	725	720	735	735	735	735	735	735	735		5			649	675	676	648			
700	775	775	800	795	820	840	840	840	840	840	840	840					751	777	778	750			
800	880	880	905	900	930	960	960	960	960	960	960	960					856	882	883	855			
900	980	980	1005	1000	1030	1070	1070	1070	1070	1070	1070	1070					961	987	988	960			
1000	1080	1080	1110	1115	1140	1180	1180	1180	1180	1180	1180	1180			6,5	6,0	4,0	1062	1092	1094	1060	28°	4
1200	1280	1295	1330	1330	1350	1380	1380	1380	1380	1380	1380	1380					1262	1292	1294	1260			
1400	1480	1510	1535	1530	1560	1600	1600	1600	1600	1600	1600	1600					1462	1492	1494	1460			
1600	1690	1710	1760	1750	1780	1815	1815	1815	1815	1815	1815	1815					1662	1692	1694	1660			
1800	1890	1920	1960	1950	1985	-	-	-	-	-	-	-					1862	1892	1894	1860			
2000	2090	2125	2170	2150	2210	-	-	-	-	-	-	-					2062	2092	2094	2060			
2200	2295	2335	2370	-	-	-	-	-	-	-	-	-					-	-	-	-			
2400	2495	2545	2570	-	-	-	-	-	-	-	-	-					-	-	-	-			
2600	2695	2750	2780	-	-	-	-	-	-	-	-	-					-	-	-	-			
2800	2910	2960	3000	-	-	-	-	-	-	-	-	-					-	-	-	-			
3000	3110	3160	3210	-	-	-	-	-	-	-	-	-					-	-	-	-			
3200	3310	3370	-	-	-	-	-	-	-	-	-	-					-	-	-	-			
3400	3510	3580	-	-	-	-	-	-	-	-	-	-					-	-	-	-			
3600	3720	3790	-	-	-	-	-	-	-	-	-	-					-	-	-	-			
3800	3920	-	-	-	-	-	-	-	-	-	-	-					-	-	-	-			
4000	4120	-	-	-	-	-	-	-	-	-	-	-					-	-	-	-			

^a Powierzchnie uszczelniające kotłownicy typów C, D, E, F, G i H nie są stosowane dla PN 2,5 i 6.

^b Powierzchnie uszczelniające kotłownicy typów G i H są stosowane tylko dla PN 10 do PN 40.

Typ C i D

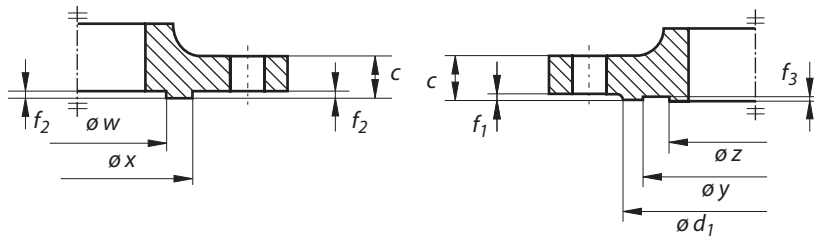

Typ C: Wypst

Typ D: Rowek

DN	Ø d1	Wypst			Rowek			
		Ø W	Ø x	f2	Ø Z	Ø y	f1	f3
10	Średnica przyłgi zgodna z zestawieniem wymiaru przyłg	24	34	4,5	23	35	2,0	4,0
15		29	39	4,5	28	40	2,0	4,0
20		36	50	4,5	35	51	2,0	4,0
25		43	57	4,5	42	58	2,0	4,0
32		51	65	4,5	50	66	2,0	4,0
40		61	75	4,5	60	76	3,0	4,0
50		73	87	4,5	72	88	3,0	4,0
65		95	109	4,5	94	110	3,0	4,0
80		106	120	4,5	105	121	3,0	4,0
100		129	149	5,0	128	150	3,0	4,5
125		155	175	5,0	154	176	3,0	4,5
150		183	203	5,0	182	204	3,0	4,5
200		239	259	5,0	238	260	3,0	4,5
250		292	312	5,0	291	313	3,0	4,5
300		343	363	5,0	342	364	4,0	4,5
350		395	421	5,5	394	422	4,0	5,0
400		447	473	5,5	446	474	4,0	5,0
450		497	523	5,5	496	524	4,0	5,0
500		549	575	5,5	548	576	4,0	5,0
600		649	675	5,5	648	676	5,0	5,0
700	751	777	5,5	750	778	5,0	5,0	
800	856	882	5,5	855	883	5,0	5,0	
900	961	987	5,5	960	988	5,0	5,0	
1000	1062	1092	6,5	1060	1094	5,0	6,0	
1200	1262	1292	6,5	1260	1294	5,0	6,0	
1400	1462	1492	6,5	1460	1494	5,0	6,0	
1600	1662	1692	6,5	1660	1694	5,0	6,0	
1800	1862	1892	6,5	1860	1894	5,0	6,0	
2000	2062	2092	6,5	2060	2094	5,0	6,0	

Powierzchnie uszczelniające kotnierzy typów C i D nie są stosowane dla PN 2,5 i 6.
Grubość C zgodna z normą

Typ E i F

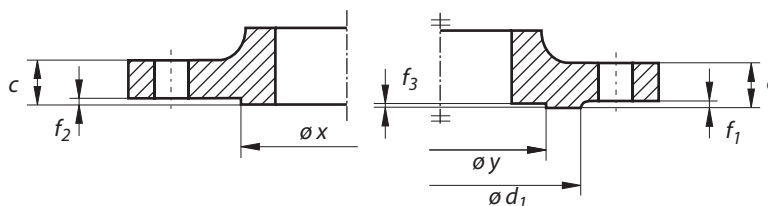

Typ E: Wypust

Typ F: Wpust

DN	Ø d1	Wypust		Wpust		
		Ø x	f2	Ø y	f1	f3
10	Średnica przyłgi zgodna z zestawieniem wymiaru przyłg	34	4,5	35	2,0	4,0
15		39	4,5	40	2,0	4,0
20		50	4,5	51	2,0	4,0
25		57	4,5	58	2,0	4,0
32		65	4,5	66	2,0	4,0
40		75	4,5	76	3,0	4,0
50		87	4,5	88	3,0	4,0
65		109	4,5	110	3,0	4,0
80		120	4,5	121	3,0	4,0
100		149	5,0	150	3,0	4,5
125		175	5,0	176	3,0	4,5
150		203	5,0	204	3,0	4,5
200		259	5,0	260	3,0	4,5
250		312	5,0	313	3,0	4,5
300		363	5,0	364	4,0	4,5
350		421	5,5	422	4,0	5,0
400		473	5,5	474	4,0	5,0
450		523	5,5	524	4,0	5,0
500		575	5,5	576	4,0	5,0
600		675	5,5	676	5,0	5,0
700		777	5,5	778	5,0	5,0
800		882	5,5	883	5,0	5,0
900		987	5,5	988	5,0	5,0
1000		1092	6,5	1094	5,0	6,0
1200		1292	6,5	1294	5,0	6,0
1400		1492	6,5	1494	5,0	6,0
1600		1692	6,5	1694	5,0	6,0
1800		1892	6,5	1894	5,0	6,0
2000	2092	6,5	2094	5,0	6,0	

Powierzchnie uszczelniające kołnierzy typów C i D nie są stosowane dla PN 2,5 i 6.

Grubość C zgodna z normą

Typ G i H

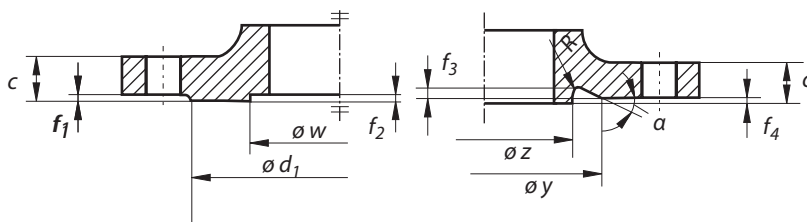

Typ G: Wypust do uszczelki o przekroju kołowym

Typ H: Rowek na uszczelkę o przekroju kołowym

DN	Ø d1	Wypust do uszczelki o przekroju kołowym			Rowek na uszczelkę o przekroju kołowym			
		Ø W	f1	f2	Ø y	Ø Z	f3	f4
10	Średnica przyłgi zgodna z zestawieniem wymiaru przyłg	24	2,0	4,5	35	23	4,0	2,0
15		29	2,0	4,5	40	28	4,0	2,0
20		36	2,0	4,5	51	35	4,0	2,0
25		43	2,0	4,5	58	42	4,0	2,0
32		51	2,0	4,5	66	50	4,0	2,0
40		61	3,0	4,5	76	60	4,0	2,0
50		73	3,0	4,5	88	72	4,0	2,0
65		95	3,0	4,5	110	94	4,0	2,0
80		106	3,0	4,5	121	105	4,0	2,0
100		129	3,0	5,0	150	128	4,5	2,5
125		155	3,0	5,0	176	154	4,5	2,5
150		183	3,0	5,0	204	182	4,5	2,5
200		239	3,0	5,0	260	238	4,5	2,5
250		292	3,0	5,0	313	291	4,5	2,5
300		343	4,0	5,0	364	342	4,5	2,5
350		395	4,0	5,5	422	394	5,0	3,0
400		447	4,0	5,5	474	446	5,0	3,0
450		497	4,0	5,5	524	496	5,0	3,0
500		549	4,0	5,5	575	548	5,0	3,0
600		649	5,0	5,5	676	648	5,0	3,0
700	751	5,0	5,5	778	750	5,0	3,0	
800	856	5,0	5,5	883	855	5,0	3,0	
900	961	5,0	5,5	988	960	5,0	3,0	
1000	1062	5,0	6,5	1094	1060	6,0	4,0	
1200	1262	5,0	6,5	1294	1260	6,0	4,0	
1400	1462	5,0	6,5	1494	1460	6,0	4,0	
1600	1662	5,0	6,5	1694	1660	6,0	4,0	
1800	1862	5,0	6,5	1894	1860	6,0	4,0	
2000	2062	5,0	6,5	2094	2060	6,0	4,0	

Powierzchnie uszczelniające kołnierzy typów G i H nie są stosowane dla PN 2,5 i 6.
 Powierzchnie uszczelniające kołnierzy typów G i H są stosowane tylko dla PN 10 do PN 40.
 Grubość C zgodna z normą